

CC-I2C_SLV-APB I2C Slave Serial Interface Controller

Symbol

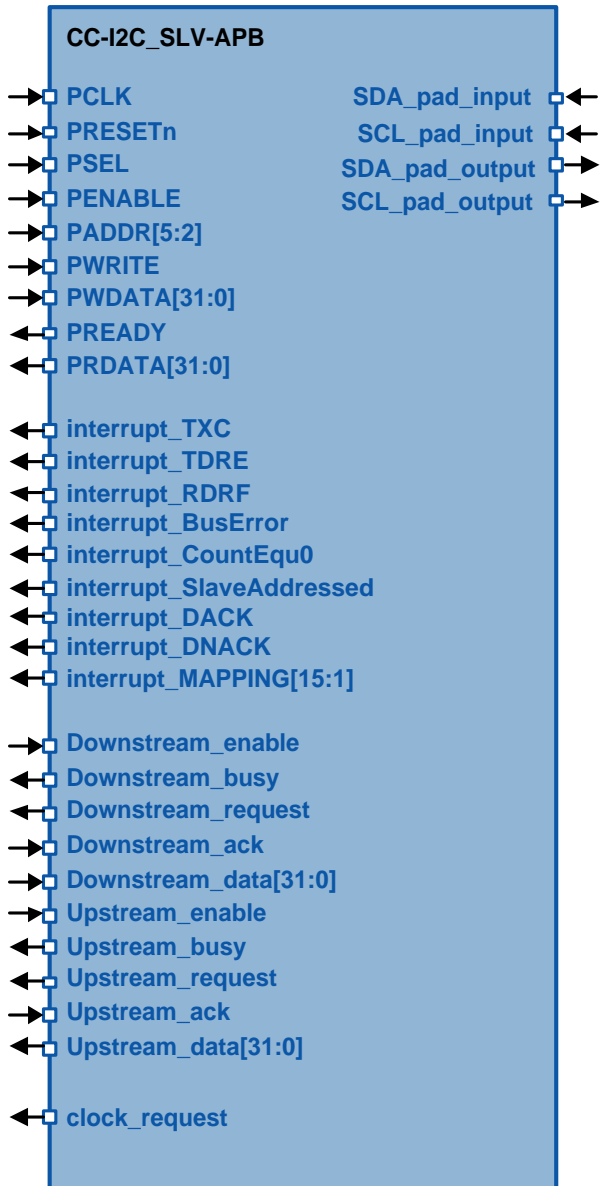

Features

- I2C-compatible interface
- AMBA APB3 bus
- Configurable setup/hold times
- Automatic clock stretching support
- Programmable SDA/SCL input filter
- Automatic Acknowledge support
- Dual addressing capability
- General call address recognition
- 7 and 10 bit addressing format support
- Maskable interrupts
- Dedicated upstream and downstream DMA interface
- Fully synthesizable synchronous design with positive edge clocking
- DFT ready

Benefits

- Supplied as human-readable Verilog RTL source code
- Technology independent IP Core
- Suitable for FPGA and ASIC
- Easy SoC integration
- Full implementation and maintenance support with individual approach
- Flexible licensing scheme

Generic Parameters

Generic name	Description	Type	Range
PDMA_support	Configure PDMA interface support	integer	0, 1
i2cCountWidth	Configure data counter width	integer	1:32
I2cSignalSampleCountWidth	Configure input sample counter width	integer	1:32
dual_address_support_enable	Copnfigure support for secondary address recongnition	integer	0, 1
interface_input_synchronization_enable	Configure SDA and SCL synchronizing flip flaps	integer	0, 1
interface_inputs_filter_enable	Configure SDA and SCL input filter	integer	0, 1
default_interrupt_MAPPING	Reset value of interrupt_MAPPING register	integer	0:32767

Integration example

- Using clock_request pin for low power mode:

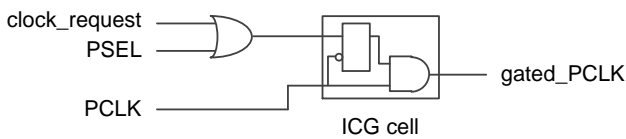

- Pad connection example:

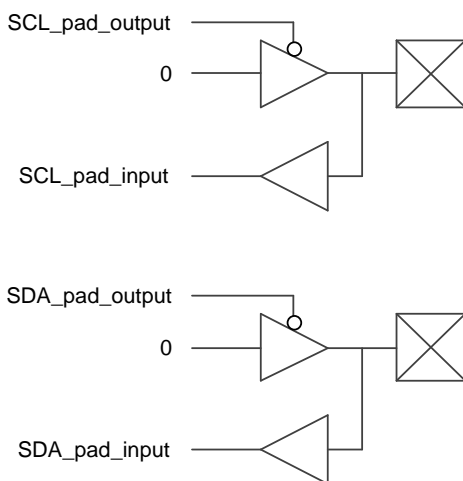

Pin-out Description

Pin name	Description	I/O	Active
PCLK	Synchronous clock	I	rising
PRESETn	Asynchronous reset	I	low
PSEL	APB peripheral select	I	high
PENABLE	APB bus enable	I	high
PADDR[5:2]	APB bus address	I	data
PWRITE	APB bus write	I	high
PWDATA[31:0]	APB bus write data	I	data
PREADY	APB bus ready	O	high
PRDATA[31:0]	APB bus read data	O	data
interrupt_TXC	Transmission complete interrupt	O	high
interrupt_TDRE	Transmit data register empty interrupt	O	high
interrupt_RDRF	Read data register full interrupt	O	high
interrupt_DNACK	Data NACK received interrupt	O	high
interrupt_DACK	Data ACK received interrupt	O	high
interrupt_CountEQ0	Count equals zero interrupt	O	high
interrupt_SlaveAddressed	Module addressed interrupt	O	high
interrupt_BusError	Protocol error interrupt	O	high
interrupt_ArbitrationLost	Arbitration lost interrupt	O	high
interrupt_MAPPING[15:1]	Interrupt mapping vector	O	data
Downstream_enable	PDMA downstream enable signal	I	high
Downstream_busy	PDMA downstream busy signal	O	high
Downstream_request	PDMA downstream request signal	O	high
Downstream_ack	PDMA downstream ack signal	I	high
Downstream_data[31:0]	PDMA downstream data	I	data
Upstream_enable	PDMA upstream enable signal	I	high
Upstream_busy	PDMA upstream busy signal	O	high
Upstream_request	PDMA upstream request signal	O	high
Upstream_ack	PDMA upstream ack signal	I	high
Upstream_data[31:0]	PDMA upstream data	O	data
clock_request	Clock request signal	O	high
SDA_pad_input	I2C data pin input	I	As I2C spec.
SCL_pad_input	I2C clock pin input	I	As I2C spec.
SDA_pad_output	I2C data pin output	O	As I2C spec.
SCL_pad_output	I2C clock pin output	O	As I2C spec.

