

1 KHZ TEMPERATURE STABLE RC OSCILLATOR

Name		Description	
CCOSC1k40A		Low power 1 kHz temperature stable RC Oscillator for RTC subsystem	
Category	Type	Status	
Clock Synthesis	RC Oscillator	GDS	
Foundry	Technology	Process Node	Year
TSMC	CMOS	40 nm	2025
Deliverables (preferable IP merge model)			
<ul style="list-style-type: none"> ◆ Datasheet ◆ Characterization report ◆ Encrypted Flat Extracted netlist with parasitic ◆ Behavioral models 		<ul style="list-style-type: none"> ◆ Abstract View ◆ Timing View ◆ DRC, LVS and antenna report ◆ Integration guidelines and support 	

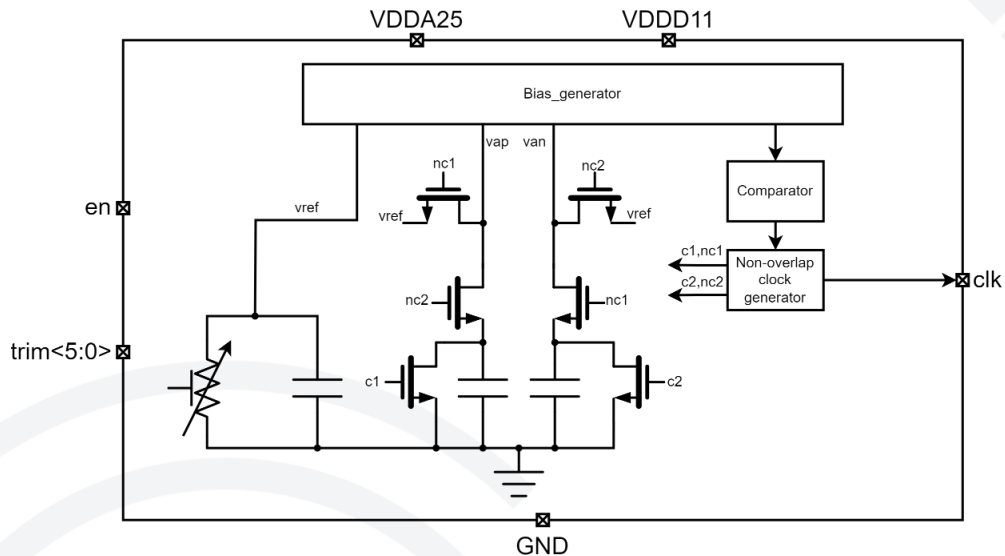

Figure 1. Simplified block diagram.

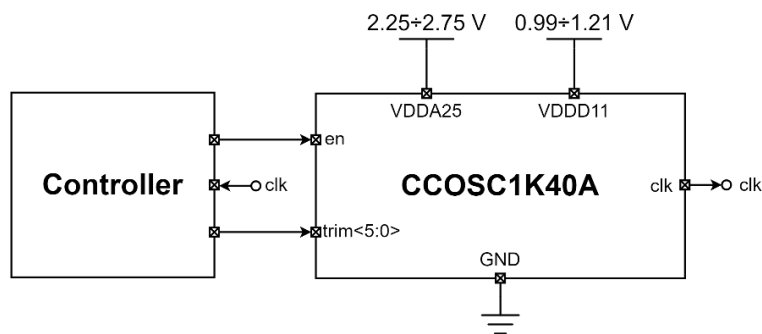

Figure 2. Typical use case.

Table 1. Pin description.

Pin name	Direction	Type	Active	Description
VDDA25	I/O	Power		2.5 V supply
VDDD11	I/O	Power		1.1 V supply
GND	I/O	Power		Ground
en	I	Digital		Enable signal (1.1 V domain)
trim<5:0>	I	Digital		Trimming input for regulating frequency to mitigate process corner effects (1.1 V domain)
clk	O	Digital		Output clock signal (1.1 V domain)

Table 2. Specification.

Parameter	Description	Min.	Typ.	Max.	Unit
T_j	Operating junction temperature	-40	27	85	°C
V_{DDA25}	Main supply voltage	2.25	2.5	2.75	V
V_{DDA11}	Supply voltage for digital and output stage	0.99	1.1	1.21	V
F_{out}	Output frequency – after factory trimming	0.99	1	1.07	kHz
	Duty cycle	48	50	52	%
Active current consumption		1.635	2.018	3.868	μA
Power down current consumption		1.15	11.5	1250	nA