

PROGRAMMABLE BROWN-OUT DETECTOR

| Name | | Description | |
|--|------------|---|--------|
| CCBOD1V1CORE40A2 | | Programmable Brown-Out Detector for 1.1 V core supply voltage | |
| Category | | Type | Status |
| Power Management | | BOD | GDS |
| Foundry | Technology | Process Node | Year |
| TSMC | CMOS | 40 nm | 2025 |
| Deliverables (preferable IP merge model) | | | |
| <ul style="list-style-type: none"> ◆ Datasheet ◆ Characterization report ◆ Encrypted Flat Extracted netlist with parasitic ◆ Behavioral models | | <ul style="list-style-type: none"> ◆ Abstract View ◆ Timing View ◆ DRC, LVS and antenna report ◆ Integration guidelines and support | |

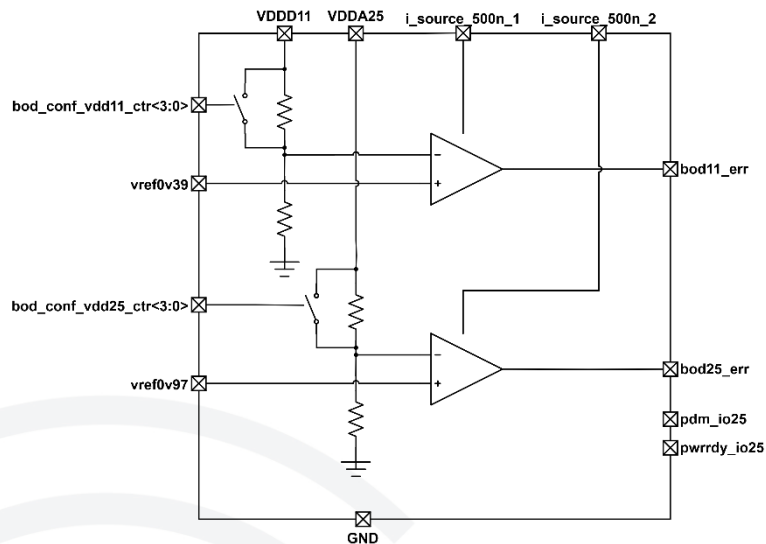

Figure 1. Simplified block diagram.

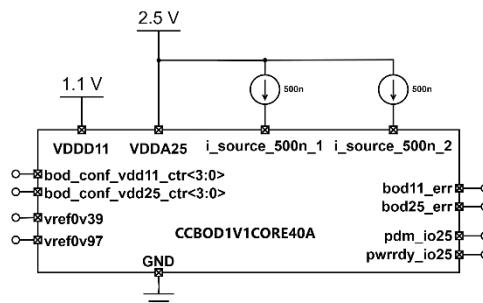

Figure 2. Typical use case.

Table 1. Pin description.

| Pin name | Direction | Type | Active | Description |
|--------------------------|-----------|---------|--------|--|
| VDDA25 | I/O | Power | | 2.5 V supply voltage |
| VDDD11 | I/O | Power | | 1.1 V supply voltage |
| GND | I/O | Power | | Ground |
| bod_conf_vdd11_en | I | Digital | High | Enable for 1.1 V voltage control |
| bod_conf_vdd25_en | I | Digital | High | Enable for 2.5 V voltage control |
| bod_conf_vdd11_ctr <3:0> | I | Digital | | Threshold for 1.1 V voltage control 1111-lowest |
| bod_conf_vdd25_ctr <3:0> | I | Digital | | Threshold for 1.1 V voltage control 1111-lowest |
| vref0v39 | I | Analog | | Input 0.39 V reference voltage |
| vref0v97 | I | Analog | | Input 0.97 V reference voltage |
| I_source_500n_1 | I/O | Analog | | Input biasing 500 nA current from PMOS transistor on VDDA25 supply |
| I_source_500n_2 | I/O | Analog | | Input biasing 500 nA current from PMOS transistor on VDDA25 supply |
| bod11_err | O | Digital | | Output of BOD testing VDD11 supply |
| bod25_err | O | Digital | | Output of BOD testing VDD25 supply |
| pdm_io25 | O | Digital | | Power isolation enable. Output in 2.5 V domain |
| pwrrdy_io25 | O | Digital | | Power ready. Output in 2.5 V domain |

Table 2. Specification.

| Parameter | Description | Min. | Typ. | Max. | Unit |
|---------------------------------|--|--------|--------|--------|------|
| T_j | Operating junction temperature | -40 | 27 | 85 | °C |
| V_{BOD2V5} | Brown out detection level for 2.5 V supply voltage | 2.049 | 2.051 | 2.053 | V |
| V_{BOD1V1} | Brown out detection level for 1.1 V supply voltage | 901.39 | 903.39 | 905.39 | mV |
| V_{BOD2V5} Hysteresis | Hysteresis for 2.5 V supply voltage | 16 | 20 | 24 | mV |
| V_{BOD1V1} hysteresis | Hysteresis for 1.1 V supply voltage | 18 | 22 | 25 | mV |
| $V_{trim2V5}$ | Brown out detection trimming step for 2.5 V supply voltage | | 80 | | mV |
| $V_{trim1V1}$ | Brown out detection trimming step for 1.1 V supply voltage | | 50 | | mV |
| V_{DDA25} current consumption | Brown out detection current consumption for 2.5 V supply voltage | 463.86 | 541.5 | 651.05 | nA |
| V_{DDA11} current consumption | Brown out detection current consumption for 1.1 V supply voltage | 3.66 | 3.87 | 4.18 | μA |