

# BANDGAP VOLTAGE REFERENCE

Name		Description	
CCBGP1V1N40A		1.1 V Bandgap Voltage Reference	
Category		Type	Status
Power Management		BGVR	GDS
Foundry	Technology	Process Node	Year
TSMC	CMOS	40 nm	2025
Deliverables (preferable IP merge model)			
<ul style="list-style-type: none"> <li>◆ Datasheet</li> <li>◆ Characterization report</li> <li>◆ Encrypted Flat Extracted netlist with parasitic</li> <li>◆ Behavioral models</li> </ul>		<ul style="list-style-type: none"> <li>◆ Abstract View</li> <li>◆ Timing View</li> <li>◆ DRC, LVS and antenna report</li> <li>◆ Integration guidelines and support</li> </ul>	

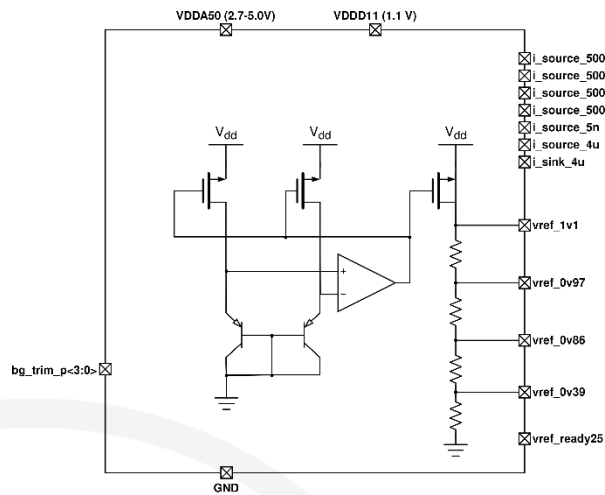

Figure 1. Simplified block diagram.

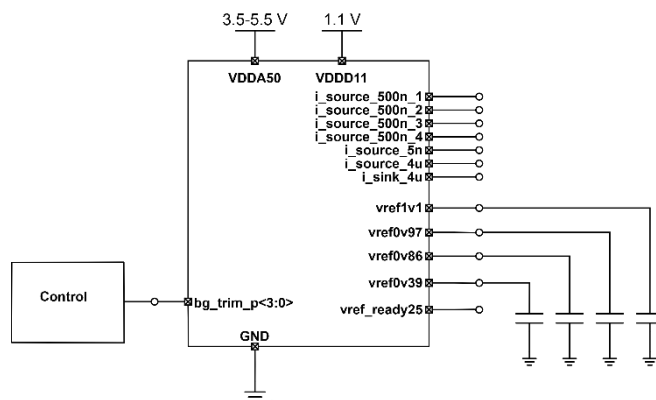

Figure 2. Typical use case.

Table 1. Pin description.

Pin name	Direction	Type	Active	Description
VDDD11	I/O	Power		1.1 V supply
VDDA50	I/O	Power		5.0 V power supply, tolerance 3.5 V to 5.5 V
GND	I/O	Power		Ground
bg_trim_p<3:0>	I	Digital		Bandgap voltage reference trimming '0111' - typical
vref1v1	O	Analog		1.1 V reference voltage
vref0v97	O	Analog		0.97 V reference voltage
vref0v86	O	Analog		0.86 V reference voltage
vref0v39	O	Analog		0.39 V reference voltage
vref_ready25	O	Digital		Signal indicating that vref is up and running
i_source_500n_1	O	Analog		Current reference for BOD
i_source_500n_2	O	Analog		Current source for BOD
i_source_500n_3	O	Analog		Current source for LDO
i_source_500n_4	O	Analog		Current source for LDO
i_source_5n	O	Analog		Current source for POR
i_source_4u	O	Analog		Current source
i_sink_4u	O	Analog		Current sink

Table 2. Specification.

Parameter	Description	Min.	Typ.	Max.	Unit
T <sub>j</sub>	Operating junction temperature	-40	27	125	°C
VDDA50	Supply voltage	3.5	5.0	5.5	V
VDDD11	Core supply voltage	0.99	1.1	1.21	V
V <sub>ref</sub> 1.1 @27°C	1.1 V voltage reference at 27°C	1.096	1.096	1.098	V
V <sub>ref</sub> 0.8 @27°C	0.8 V voltage reference at 27°C	794.8	794.9	796.6	mV
V <sub>ref</sub> 1.1	1.1 V voltage reference	1.089	-	1.099	V
V <sub>ref</sub> 0.8	0.8 V voltage reference	795.1	-	796.9	mV
TC	Temperature coefficient	32.03	40.58	43.31	ppm/°C
I <sub>c</sub>	Current consumption	6.455	7.591	9.222	µA
I <sub>OFF</sub>	Disabled block power consumption	1.845	2.449	4.085	nA
PSRR	Power supply rejection ratio – slow start mode	25.2	27.54	29.44	dB
	Power supply rejection ratio – fast start mode	35.18	35.45	35.69	dB
RT 90%	Rising time from 10 to 90% of vref value – slow start mode	142.1	184.9	252.8	us