

10-CHANNEL 12-BIT 2 MSPS ADC

Name		Description		
CCADC12B2M10CH40A		10-channel 12-bit 2 Msp/s Analog-to-Digital Converter		
Category		Type	Status	
Data Converters		ADC	GDS	
Foundry	Technology	Process Node	Year	
TSMC	CMOS	40 nm	2025	
Deliverables (preferable IP merge model)				
<ul style="list-style-type: none"> ◆ Datasheet ◆ Characterization report ◆ Encrypted Flat Extracted netlist with parasitic ◆ Behavioral models 		<ul style="list-style-type: none"> ◆ Abstract View ◆ Timing View ◆ DRC, LVS and antenna report ◆ Integration guidelines and support 		

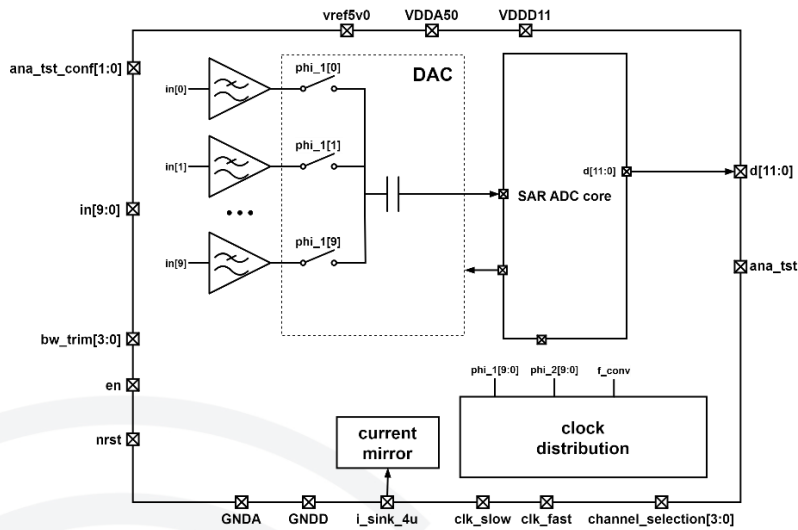

Figure 1. Simplified block diagram.

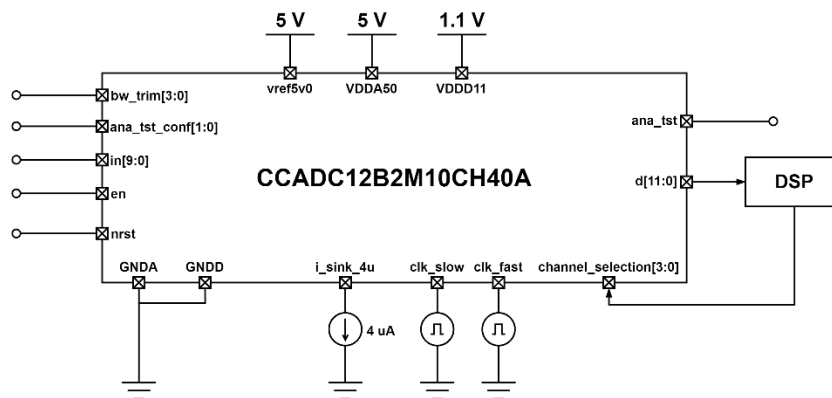

Figure 2. Typical use case.

Table 1. Pin description.

Pin name	Direction	Type	Active	Description
in[9:0]	I	Analog		Input voltage signal Bus
channel_selection[3:0]	I	Digital		Channel selection word
d[11:0]	O	Digital		Output 12-bit word
i_sink_4u	I/O	Analog		Input 4 uA reference signal
en	I	Digital		Enable signal in 1.1 V domain
vref5v0	I/O	Power		ADC reference signal
clk_slow	I	Digital		Digital clock input 2 MHz
clk_fast	I	Digital		Digital clock input 16 MHz
bw_trim[3:0]	I	Digital		Digital input trimming control of anti-aliasing filter bandwidth
ana_tst	O	Analog		Analog test signal
ana_tst_conf [1:0]	I	Digital		Test signal configuration
GNDA	I/O	Power		Analog Ground
GNDD	I/O	Power		Digital Ground
VDDA50	I/O	Power		Analog Supply
VDDD11	I/O	Power		Digital Supply

Table 2. Specification.

Parameter	Description	Min.	Typ.	Max.	Unit
Resolution	Number of bits		12		-
ENOB	Effective Number of Bits	10	0	0	-
Tj	Operating junction temperature	-40	0	85	°C
Fs	Sampling Rate	0	2	0	MHz
VDDA	Supply Voltage Analog Domain	3.5	5	5.5	V
VDDD	Supply Voltage Digital Domain	0.99	1.1	1.21	V
Missing codes	0	0	No	0	-
DNL	Differential nonlinearity	-0.5	0	0.5	LSB
INL	Integral nonlinearity	-0.5	0	0.5	LSB
SNR	Vin=-1dBFS	62.66	0	0	dBFS
SNDR	Vin=-1dBFS	61.96	0	0	dBFS
SFDR	Vin=-1dBFS	75	0	0	dB
Ioff	Sleep mode Power Dissipation fs=0	0	0	0.1	uA
Fc3dB	Anti-Aliasing filter 3dB corner frequency	0	1	0	MHz
FilterOrder	Anti-Aliasing filter order	0	2	0	dB
Area	Without supply decap	0	0.106	0	mm2